

- 計測 **Fx**
- 計測 **Fy**
- 計測 **Fz**
- 計測 **Mx**
- 計測 **My**
- 計測 **Mz**
- 精度 **0.2%**
- 干渉補正 **CPU**
- 形状 **薄型**
- 用途 **汎**
- 付属 **CAL**
- CABLE **5m**

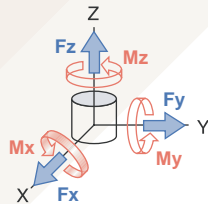

2-connector type

6分力

分力
6

LMC-6567A

サイズ 100×H54

型式 TYPE	定格負荷 (許容荷重・許容モーメント) RATED LOAD (Allowable Load/Allowable Moment)					
	(N) Fx	(N) Fy	(N) Fz	(Nm) Mx	(Nm) My	(Nm) Mz
LMC-6567A-2N	±2	±2	±4	±0.1	±0.1	±0.1
-5N	±5	±5	±10	±0.3	±0.3	±0.3
-10N	±10	±10	±20	±0.7	±0.7	±0.7
-20N	±20	±20	±40	±1.5	±1.5	±1.5
-50N	±50	±50	±100	±3.5	±3.5	±3.5
-100N	±100	±100	±200	±7	±7	±7
-200N	±200	±200	±400	±15	±15	±15
-500N	±500	±500	±1000	±35	±35	±35
-1000N	±1000	±1000	±2000	±70	±70	±70

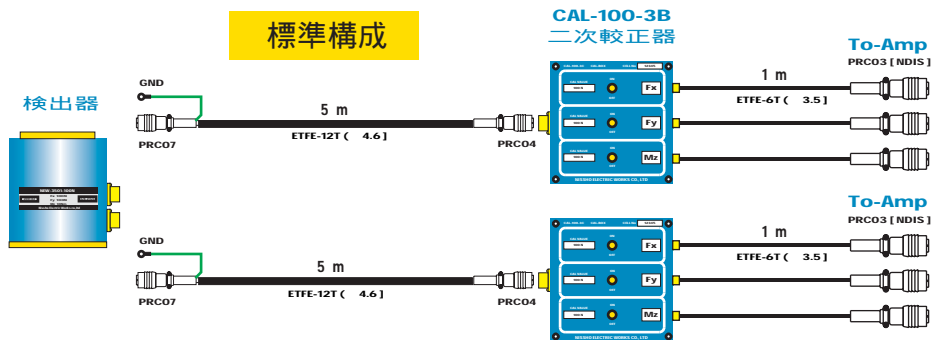

薄型 6 分力検出器
LMC SERIES

日章電機株式会社

50-1